

Technical Data

alkitronic® - EFCip / EFCip plus

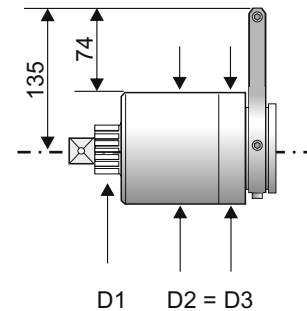

EFCip 100 / EFCip 100plus



EFCip / EFCip...plus

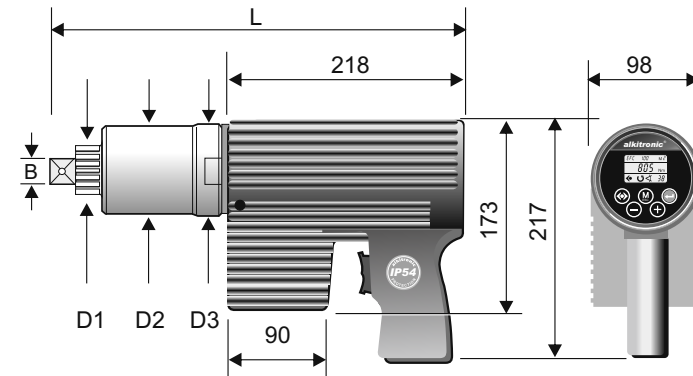

Annotations:

Torque ranges are in accordance with the torque chart.

The following torque ranges are theoretical standard dates based on an aligned tool electronic.

Repeatable accuracy for switch off $\pm 3\%$ for identically soft and hard joints.

Depending on soft and hard joints M_0 deviations are possible.

Series EFCip/EFCip..plus	Type	EFCip 10	EFCip 20	EFCip 30	EFCip 40	EFCip 50	EFCip 60	EFCip 65	EFCip 70	EFCip 80	EFCip 90	EFCip 100
Torque range*	Nm	70-400	80-600	150-1000	250-1500	300-1800	450-2500	500-3000	600-3500	800-4200	1000-5000	1300-6300
Square drive	B	3/4"	3/4"	3/4"	1"	1"	1"	1" / 1 1/2"	1" / 1 1/2"	1 1/2"	1 1/2"	1 1/2"
Diameter D ₁ approx.	mm	41	41	41	54	54	54	54/72	72	72	72	72
Diameter D ₂ approx.	mm	85	85	85	85	85	85	85	98	98	123	123
Diameter D ₃ approx.	mm	88	88	88	88	88	88	88	98	98	123	123
Length L	mm	330	330	330	382	382	388	388	400/406	406	428	436
Weight without support approx.	kg	9,0	9,0	9,0	10,0	10,0	11,0	11,0	13,2	13,2	17,5	18,5
Idle speed approx.	rmin ⁻¹	76	38	24	15	13	12	12	9	7	6	4

* Attention: Loosening torque of bolt might be up to 20% higher. Take care to secure and stable the reaction support.

Subject to change without prior notice / E & OE / Figures can differ depending on type.